

# ANSI 150# Cast Iron GLOBE VALVES



### Features

- ANSI 150# Flange Connection
- Size: 2" – 4" (DN50 – DN100)
- Valve Body Material: Cast Iron
- Working Pressure: 150#
- Applicable Medium: General oil, gas and water applications
- Temperature Range:  $\leq 205^{\circ}\text{C}$



ANSI 150# Cast Iron  
Flange End Globe Valves

### Material List

No.	Part Name	Material
1	Body	A126 B Cast Iron
2	Seat	A126 B Cast Iron
3	Disc	A126 B Cast Iron
4	Cover	A29 1025
5	Stem	A276 SUS410
6	Gasket	SS304 + Graphite
7	Bolts	A29 1035
8	Nuts	A29 1025
9	Bonnet	A126 B Cast Iron
10	Stem Nut	A276 SUS410
11	Handwheel	A47 32510 Malleable Iron
12	Nut	A29 1025
13	Screw	SS304
14	Nut	A29 1025
15	Bolt	A29 1035
16	Gland Flange	A126 B Cast Iron
17	Packing Gland	A276 SUS410
18	Pin	A29 1025
19	Packing	Flexible Graphite

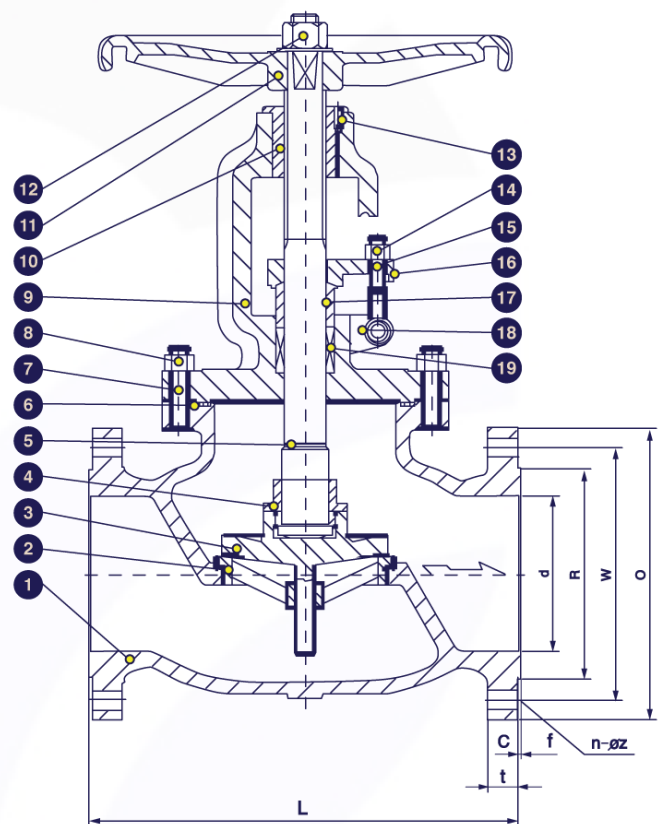

Pressure Test	Class 150	
Hydraulic body test pressure	2.06	MPa
Seal test pressure	1.57	
Hermetical Sealing Test	0.6	
Applicable Medium: General oil, gas & Water		

## Features

- ANSI 150# Flange Connection
- Size: 5" –6" (DN125 – DN150)
- Valve Body Material: Cast Iron
- Working Pressure: 150#
- Applicable Medium: General oil, gas and water applications
- Temperature Range:  $\leq 429^{\circ}\text{C}$



ANSI 150# Cast Iron  
Flange End Globe Valves

## Material List

No.	Part Name	Material
1	Body	ASTM A126 B
2	Seat	ASTM A126 B + SS304
3	Disc	ASTM A126 B + SS304
4	Cover	ASTM A29 1025
5	Stem	ASTM A276 SUS410
6	Gasket	SS304 + Graphite
7	Bolts	ASTM A29 1035
8	Nuts	ASTM A29 1025
9	Bonnet	ASTM A126 B
10	Stem Nut	ASTM A276 410
11	Handwheel	ASTM A47 32510
12	Nut	ASTM A29 1025
13	Screw	SS304
14	Nut	ASTM A29 1025
15	Bolt	ASTM A29 1035
16	Gland Flange	ASTM A126 B
17	Packing Gland	ASTM A276 410
18	Pin	ASTM A29 1025
19	Packing	Flexible Graphite

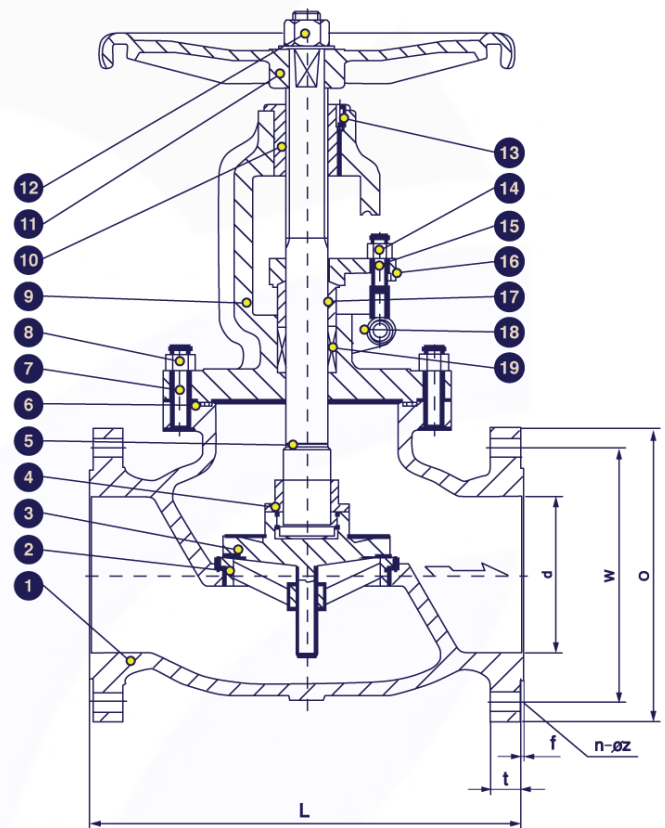

## Technical Specifications

1. Basic design and manufacture according to ASME B16.10
2. Face to face dimension: ASME B16.10
3. Flange End: ASME B16.5
4. Inspection and test: API 598

Main Technical Parameter			
Normal pressure		150 PSI	
Test pressure	Hydraulic Body test pressure	2.06	MPa
	Seat test	1.57	
	Hermetical Sealing test	0.6	
Max working temperature		$\leq 429^{\circ}\text{C}$	
Applicable Medium: General oil, gas & water			

## Ordering Information

VL	-	CI	-	GL	-	F	-	150	-	32
I		II		III		IV		V		VI

<b>I</b>	<b>Type of Item</b>		
VL	Low Pressure Valves		

<b>II</b>	<b>Material Grade</b>		
S	SS316, CF8M	CI	Cast Iron
FS	Forged Steel	CS	Cast Steel
B	Brass		

<b>III</b>	<b>Item</b>		
GA	Gate Valve	B1	1 PC Ball Valve
GL	Globe Valve	B2	2 PC Ball Valve
YS	Y-Strainer	B3	3 PC Ball Valve
SC	Swing Check Valve	BL	3 Way Ball Valve L Port
VC	Vertical Check Valve	BT	3 Way Ball Valve T Port
WC	Wafer Check Valve	BMF	Male x Female Mini Ball Valve
DD	Dual Disk	BU	Butterfly Valve

<b>IV</b>	<b>Connection Type</b>		
SW	S/W	G	BSPP
BW	B/W	N	NPT
R	BSPT	F	Flange End
W	Wafer	L	Lug

<b>V</b>	<b>Pressure</b>		
200	200 PSI	2000	2000 PSI
300	300 PSI	150	ANSI 150# Flange Standard
600	600 PSI	10K	JIS 10K Flange Standard
800	800 PSI	PN16	PN 16 Flange Standard
1000	1000 PSI		

## For Inch OD & Inch NB Sizes

<b>VI</b>	<b>Size</b>							
Size	1/8"	1/4"	5/16"	3/8"	1/2"	5/8"	3/4"	1"
Code	02	04	05	06	08	10	12	16
Size	1 1/4"	1 1/2"	2"	2 1/2"	3"	4"	5"	6"
Code	20	24	32	40	48	64	80	96

<b>VII</b>	<b>Coating</b>		
(None)	No Additional Coating		
NI	Nickel Plating		

## Dimension List

### DN50 – DN100

NPS	Part No	d	L	O	W	R	n – Øz	t	f	Weight (Kg)
2"	VL-CI-GL-F-150-32	50	200	152	120.7	92.1	4-Ø19	15.9	2	11.45
2-1/2"	VL-CI-GL-F-150-40	65	216	178	139.5	104.8	4-Ø19	17.5	2	18.80
3"	VL-CI-GL-F-150-48	80	240	190	152.5	127	4-Ø19	19.1	2	24.70
4"	VL-CI-GL-F-150-64	100	292	229	190.5	157.2	8-Ø19	23.9	2	37.25

### DN125 – DN150

NPS	Part No	d	L	O	W	n – Øz	t	f	Weight (Kg)
5"	VL-CI-GL-F-150-80	125	330	254	216	8-Ø22	23.9	2	49.50
6"	VL-CI-GL-F-150-96	150	355	279	241.5	8-Ø22	25.4	2	66.75

## Part Number Reference

Part No	Description
VL-CI-GL-F-150-32	2" 150# CI FLANGE END GLOBE VALVE RF, NON-RISING STEM
VL-CI-GL-F-150-40	2 1/2" 150# CI FLANGE END GLOBE VALVE RF, NON-RISING STEM
VL-CI-GL-F-150-48	3" 150# CI FLANGE END GLOBE VALVE RF, NON-RISING STEM
VL-CI-GL-F-150-64	4" 150# CI FLANGE END GLOBE VALVE RF, NON-RISING STEM
VL-CI-GL-F-150-80	5" 150# CI FLANGE END GLOBE VALVE RF, NON-RISING STEM,SS304 TRIM
VL-CI-GL-F-150-96	6" 150# CI FLANGE END GLOBE VALVE RF, NON-RISING STEM,SS304 TRIM



# ANSI 150 Cast Iron Globe Valves



## AF HYDRO

### Conditions of Use of Catalogue:

The information in the catalogue are not binding and in order to improve distribution, AF Hydro reserves the right to make any change including size and pressure ratings considered necessary at any time and without prior notice. According to the copyright and the civil law, any reproduction (also partial) of figures and texts of this catalogue by means of electronic, mechanical, photocopies, microfilms, recordings or other is forbidden without AF Hydro's authorization.